

Provided By:



Concrete Masonry
Checkoff

Denver

concretemasonrycheckoff.org/

If you'd like to learn more about the Concrete Masonry Checkoff, please visit our website.



CRACK CONTROL STRATEGIES FOR CONCRETE MASONRY CONSTRUCTION

INTRODUCTION

Concrete masonry is a popular construction material because its inherent attributes satisfy the diverse needs of both interior walls and exterior envelopes over a wide array of applications. While these attributes are the primary basis for concrete masonry's popularity, performance should not be taken for granted. Cracks in building assemblies and building materials may result from restrained movement originating within the material, as with volume changes due to moisture loss or gain, or from temperature expansion or contraction. Cracking may also be caused by movements of adjacent or supporting elements or systems, such as deflection of beams or settlement of foundations. In many cases, movement is inevitable and must be accommodated or controlled, which requires an understanding of the sources of stress that cause cracking. While would be a simple matter to prevent cracking if there were only one cause or variable, in reality crack mitigation requires identifying and addressing a combination of potential sources. This Tech Note reviews the common causes of cracking, from both internal and external sources, in concrete masonry construction and presents proven strategies and detailing approaches to mitigate and control shrinkage-induced cracks. The Solutions Summary section of this Tech Note provides a summary overview of these recommendations, with more detailed explanation, construction details, and background provided in the subsequent discussion.

There are many types of construction joints each with different names incorporated into masonry construction for varying purposes. In the context of this Tech Note, the following joint terms and their associated meanings are used. Other regional terms or expressions may also be used to convey the same functional intent as those here.

- Control Joint – A joint used to break up a large field of concrete masonry into discrete panels for the purpose of allowing shrinkage and mitigating cracking.
- Isolation Joint – A joint used to separate one section of concrete masonry from another to prevent the transfer of loads or to accommodate differential movement within the system.
- Movement Joint – A generic term for a joint that may be intended to serve in multiple functions or accommodate multiple sources of movement.
- Relief Joint – A weakened section of reinforced concrete masonry used to control and isolate the formation of shrinkage related cracks.
- Expansion Joint – Used primarily with clay masonry construction to accommodate the expansion of the clay masonry units; typically not used with concrete masonry construction.

SOLUTIONS SUMMARY

Shrinkage related cracking in concrete masonry construction is an aesthetic distraction from the beauty of concrete masonry and can result in reducing the functionality and performance of the building. If not addressed, shrinkage cracks can cause other issues stemming from water penetration through hairline cracks subjected to a wind-driven rain. Summarized here are common sources of cracking and recommended strategies to mitigate shrinkage-induced cracks using three alternative approaches: empirical crack control, engineered crack control, and reinforced relief joints.

Control joints should be located where volume changes in the masonry are likely to create stress concentrations that

will exceed its tensile capacity of the masonry. **FIGURES 1 AND 2** highlight several common locations for these stress concentrations and corresponding recommendations for locating control joints.

Crack control detailing practices have been developed based on successful field performance over many decades covering a wide array of common applications and exposure conditions. These practices have evolved into the empirical crack control criteria for concrete masonry walls and veneers using a combination of control joints and horizontal reinforcement as summarized in **TABLE 1**.

The engineered crack control methodology is based on a calculation of the concrete masonry assembly's Crack Control

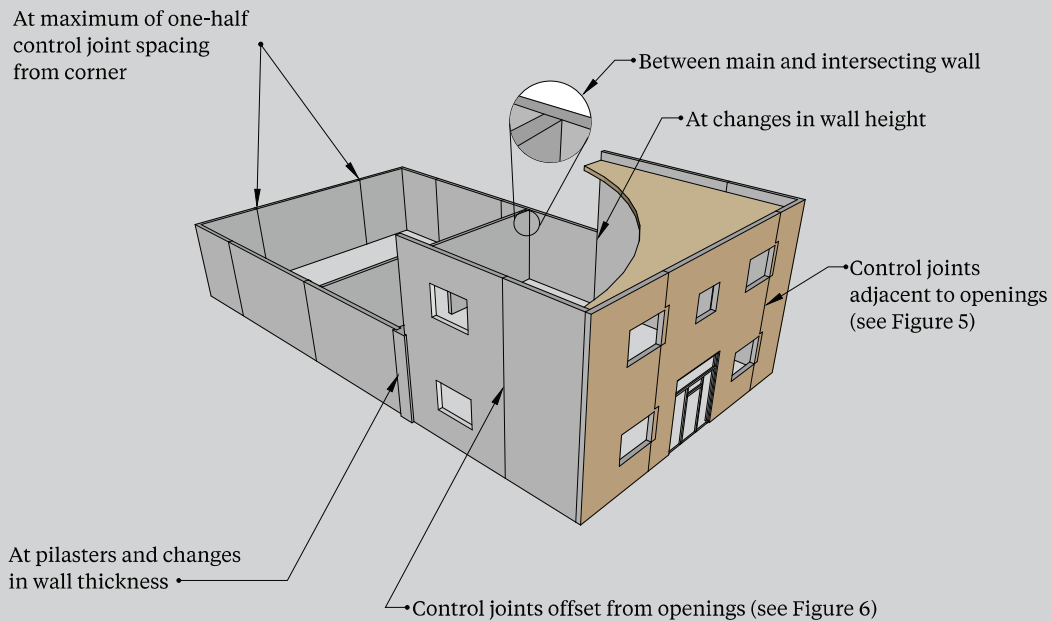

FIGURE 1 — Typical Control Joint Locations near Stress Concentrations

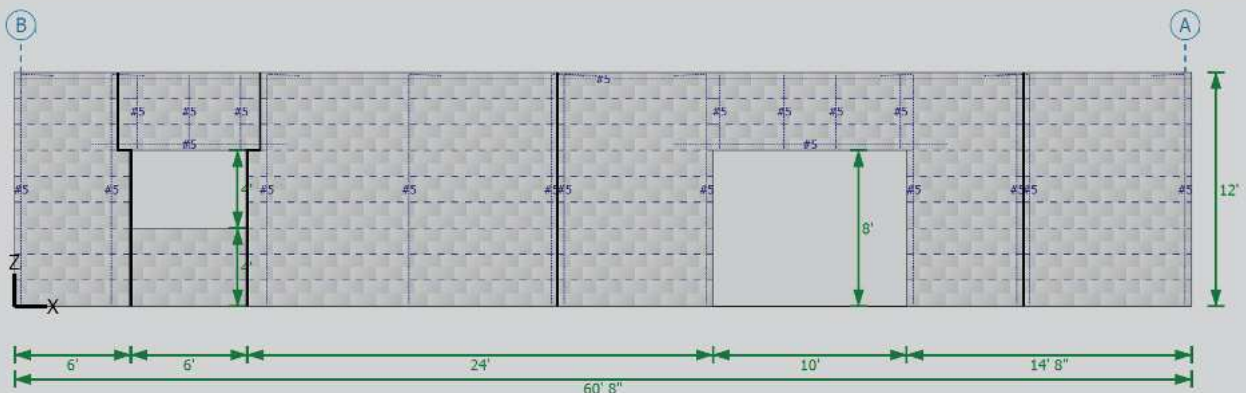

FIGURE 2 — Locating Control Joints for Isolated Opening (Window) and Reinforced Opening (Doorway)

SOLUTIONS SUMMARY (CONTINUED)

TABLE 1: Empirical Control Joint Spacing for Above Grade Concrete Masonry Walls and Anchored Veneers^A

	Maximum Length-to-Height Ratio of Concrete Masonry Panel	Maximum Control Joint Spacing
Nominal Unit Height: 8 in. (203 mm) ^B	1.5 to 1	25 ft.-4 in.(7.72 m)
Nominal Unit Height: 4 in. (102 mm) ^C	1.5 to 1	20 ft. (6.10 m)
Concrete Masonry Veneers ^{C, D}	1.5 to 1	20 ft. (6.10 m)

^AAdjust spacing as needed where local experience or project conditions warrant.
^BInclude horizontal reinforcement having an equivalent area of not less than 0.025 in.²/ft. (52.9 mm²/m) of height. See **TABLE 3**.
^CInclude horizontal reinforcement having an equivalent area of not less than 0.034 in.²/ft. (72.0 mm²/m) of height. See **TABLE 4**.
^DType N mortar recommended.

Coefficient (CCC) to predict the potential for volume loss and subsequent cracking. Similar to the empirical approach, the engineered crack control method uses a combination of horizontal reinforcement and control joints to mitigate shrinkage cracking, but is typically used in more challenging or unique applications, or when material properties are known prior to the layout of control joints, following the recommendations of **TABLE 2**.

In some applications control joints may not be necessary, such as when the area of the horizontal reinforcement exceeds

0.002 multiplied by the vertical, net cross-sectional area of the masonry assembly ($A_{SH} > 0.002A_{NV}$). This strategy is commonly employed in areas of high seismicity and similar conditions where the volume of horizontal reinforcement needed for structural load resistance precludes the need for control joints. Although control joints may not be needed for specific applications meeting the requirements of **TABLE 6**, reinforced relief joints may still be necessary when wall lengths become excessively long or when continuity of shear walls is desired for resisting in-plane loads. **FIGURES 7G, 7H, AND 7J** provide examples of reinforced relief joints.

TABLE 2: Engineered Control Joint Spacing for Above Grade Concrete Masonry Walls^{A,B}

Crack Control Coefficient (CCC) ^C	Maximum Length-to-Height Ratio of Concrete Masonry Panel	Maximum Control Joint Spacing
0.0010 in./in. (mm/mm)	2.5 to 1	25 ft.-4 in.(7.72 m)
0.0015 in./in. (mm/mm)	2 to 1	20 ft. (6.10 m)

^AAdjust spacing as needed where local experience or project conditions warrant.
^BTable values are based on a minimum horizontal reinforcement ratio (A_{SH}/A_{NV}) of 0.0007. See **TABLE 5**.
^CLinear interpolation of CCC values permitted.

1.0 CAUSES OF CRACKING

There are a variety of potential causes of cracking. Understanding the cause of potential cracking allows the designer to incorporate appropriate design strategies and details to control it. The most common causes of cracking in concrete masonry are shown in Figure 3 and are reviewed in more detail in the following discussion.

1.1 Restrained Volumetric Changes

Concrete masonry undergoes volumetric changes as a result of variations in moisture content, thermal expansion and contraction, and carbonation of the hydrated cement. While volumetric changes due to fluctuations in moisture content and temperature are reversible (carbonation shrinkage, however, is irreversible), the long-term result is a small, but cumulative, net reduction in the volume of the concrete masonry assembly stemming from these three sources. In isolation, this volumetric movement isn't the cause of cracking. When external restraint is present that resists this movement, however, the result generates tension stresses within the wall and a corresponding potential for cracking. Concrete masonry walls are restrained along the bottom by the foundation with partial restraint along the top of the wall and at discrete floor levels when connected

to diaphragms. Additional partial restraint may be present at wall intersections and corners. It's this combination of volume reduction and restraint at the edges of a concrete masonry wall that can lead to the shrinkage cracking addressed by this TEK.

1.1.1 Drying Shrinkage

Concrete products are composed of a matrix of aggregate particles coated by a cement paste that binds them together. Once the concrete sets, this cementitious-coated aggregate matrix expands with increasing moisture content and contracts (shrinks) with decreasing moisture content.

Although mortar, grout, and concrete masonry units are all concrete products, the properties of the units has historically been used as the predominate indicator of the potential overall assembly shrinkage. Variables that influence the unit (and therefore assembly) shrinkage potential include:

- Curing: Increased the time between unit production and unit installation reduces the potential for shrinkage. Some methods of curing concrete masonry units have been shown to reduce shrinkage potential.
- Moisture Content: Walls constructed with wetter units will experience more drying shrinkage than drier units. It's also

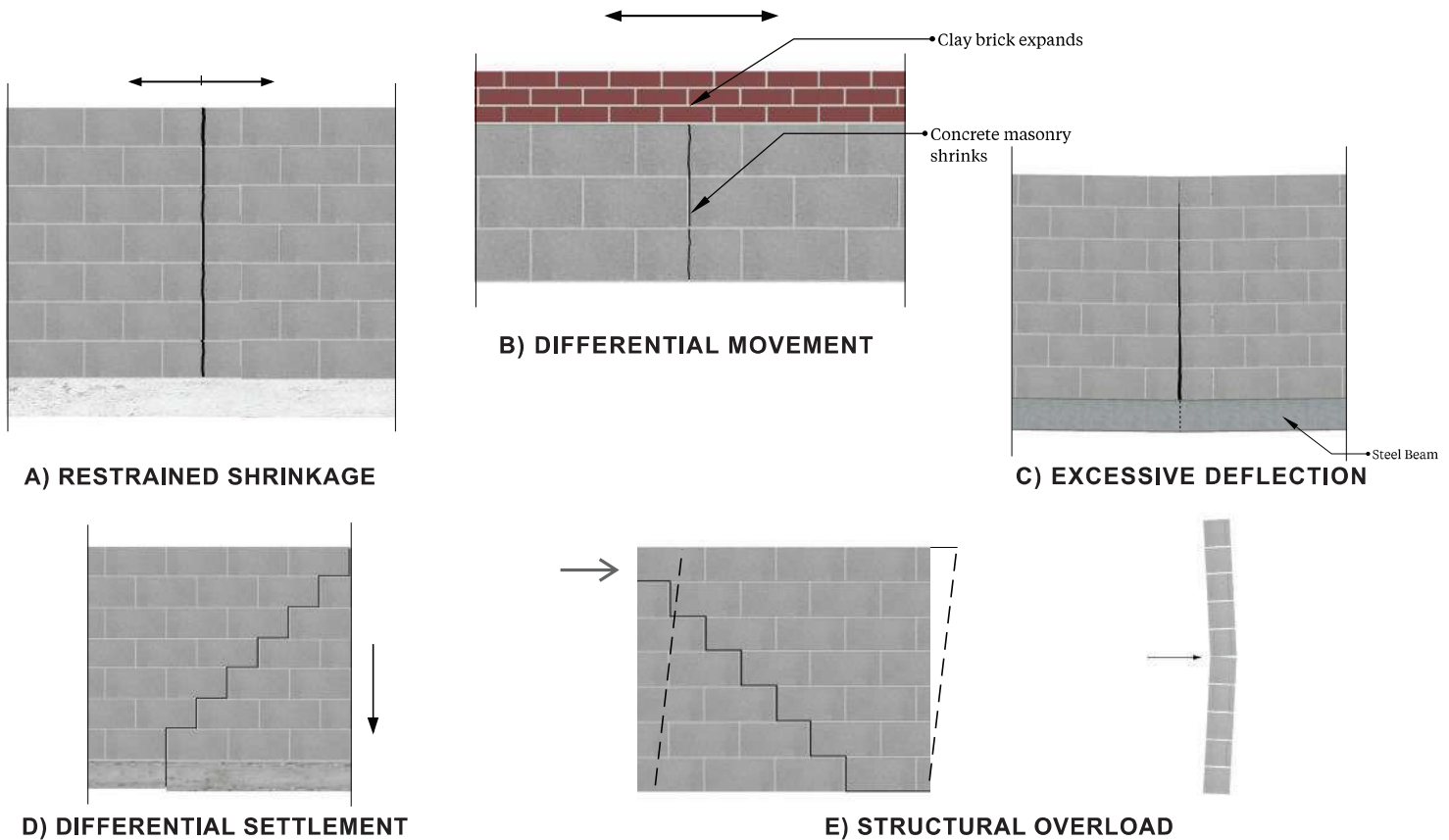

FIGURE 3 — Common Sources of Cracking in Masonry

been shown that units having undergone at least one drying cycle will not experience as much shrinkage in subsequent drying cycles (REF. 1).

- Cement: Increases in cement content increase shrinkage due to cement hydration.
- Aggregates: Aggregates that are susceptible to volume change due to moisture content will result in increased shrinkage.

Typical drying shrinkage coefficients range from 0.0002 to 0.00045 in./in. (mm/mm) when tested in accordance with ASTM C426, *Standard Test Method for Linear Drying Shrinkage of Concrete Masonry Units* (REF. 2). For design application, TMS 402, *Building Code Requirements for Masonry Structures*, (REF. 3) stipulates using 50% of the drying shrinkage measured according to ASTM C426. When tested shrinkage values are unknown, designers often conservatively use 50% of the maximum drying shrinkage permitted for concrete masonry units (REF. 5, 6, 7, 8); or 50% of 0.00065 in./in. (mm/mm).

1.1.2 Thermal Expansion and Contraction

Volumetric changes in concrete masonry is linearly proportional to changes in temperature under normal operating conditions. The coefficient of thermal expansion used in design is 0.0000045 in./in./°F (0.0000081 mm/mm/°C) (REF. 3). Actual values may range from 0.0000025 to 0.0000055 in./in./°F (0.0000045 to 0.0000099 mm/mm/°C) depending mainly on the type of aggregate used in the production of the unit, with lightweight aggregates typically experiencing volumetric change as a result in temperature fluctuations.

1.1.3 Carbonation

Carbonation is an irreversible chemical reaction between the hydrated cementitious materials in the masonry and carbon dioxide in the atmosphere. While this reaction permanently binds the carbon within the matrix of the concrete, the result of this reaction is unit shrinkage. While no standard test method currently exists for measuring the carbonation shrinkage of concrete masonry materials, a value of 0.00025 in./in. (mm/mm) has been successfully used for several decades.

1.2 Differential Movement

Various building materials react differently to changes in temperature, moisture, or structural loading. Any time materials with different properties are combined into a single wall system, the potential exists for cracking due to differential movement. With concrete masonry construction, two materials in particular should be considered: clay brick and structural steel.

Differential movement between clay brick and concrete masonry must be considered when the two are bonded together because under equivalent exposure conditions concrete masonry has an overall tendency to shrink while clay brick masonry expands. These differential movements may cause cracking, especially in composite construction and in walls that incorporate clay and concrete masonry into the same wythe. Detailing strategies for combining clay brick and concrete masonry units into a single assembly are addressed in TEK 05-02A (REF. 4C).

Thermal movement and deflection differences also need to be taken into consideration when using masonry in conjunction with structural steel. In addition to differences in the two materials' coefficients of thermal expansion, steel shapes typically have a much higher surface-area-to-volume ratio and tend to react to changes in temperature more quickly than concrete masonry.

1.3 Excessive Deflection

As masonry assemblies or their supporting elements deflect under load, cracking may occur if not properly accounted for in design. To reduce the potential for deflection-induced cracking, the following should be considered:

- adding reinforcing steel into the masonry to cross the expected cracks and to limit the width of the cracks;
- limiting the deflection of members providing vertical support of unreinforced masonry to less than or equal to $l/600$ due to unfactored dead load and live load (REF. 4C); and
- utilizing isolation joints to effectively panelize the masonry so that it can articulate with the deflected shape of the supporting member. This is commonly done when a single masonry wall is supported at different locations by different methods or systems having dissimilar stiffnesses.

1.4 Structural Overload

All wall systems are subject to potential cracking from externally applied design loads. Cracking due to these sources is controlled by applying appropriate structural design criteria.

1.5 Differential Settlement

Differential settlement occurs when portions of the supporting foundation or support structure subside due to weak or improperly compacted foundation soils. Foundation settlement typically causes a stair-step crack along the mortar joints in the settled area as shown in FIGURE 3D. Preventing settlement cracking depends on a realistic evaluation of soil bearing capacity and on proper footing design and construction. Footings should be placed on undisturbed native soil, unless this soil is unsuitable, weak, or soft. Unsuitable soil should be removed and replaced with compacted soil, gravel, or concrete. Similarly, tree roots, construction debris, and ice should be removed prior to placing footings.

2.0 CRACK CONTROL STRATEGIES

Because shrinkage cracks in concrete masonry are an aesthetic rather than a structural concern, the following crack control strategies are typically only applied to above grade assemblies where shrinkage cracking may detract from the appearance or where water ingress or air infiltration/exfiltration is a concern. In addition to properly designing for structural capacity, settlement, and differential movement, there are several alternative approaches to designing and detailing concrete masonry assemblies to limit shrinkage-related cracking:

- 1) Empirical Control Joints – This crack control criteria uses a combination of control joint spacing, detailing practices, and horizontal reinforcement derived from decades of successful practices. This commonly used method can

be applied to loadbearing and nonloadbearing concrete masonry walls where typical environmental exposures, building configurations, and use conditions prevail.

- 2) Engineered Control Joints – Similar to the empirical crack control recommendations, the engineered method is a more analytical approach to crack control based on a Crack Control Coefficient (CCC) that includes the combined effects of movement due to drying shrinkage,

carbonation shrinkage, and contraction due to temperature change. The engineered crack control approach, like the empirical method, combines control joints and reinforcement strategies to mitigate cracking, but is used when specific material properties are known or when atypical design circumstances are encountered.

- 3) Reinforced Relief Joints – When sufficient horizontal reinforcement is provided, control joints may be

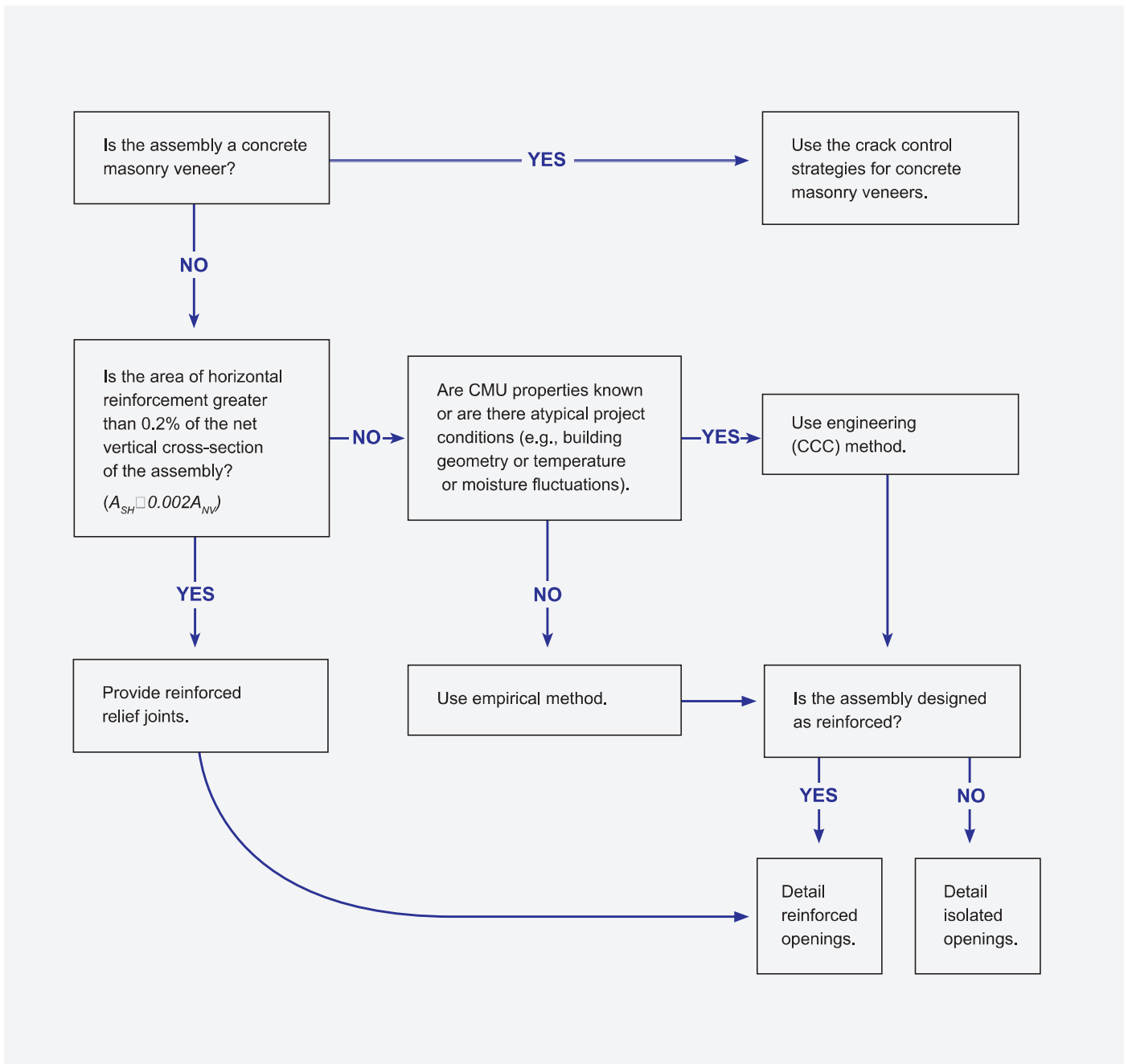

FIGURE 4 — Crack Control Alternatives Selection Matrix

eliminated. This strategy is most commonly used in cases where large lateral loads necessitate the need for large quantities of horizontal reinforcement to resist in-plane shear. While control joints may not be necessary where sufficient horizontal reinforcement is provided, relief joints may still be required, especially in long walls.

- 4) Veneer Control Joints – Given their unique characteristics compared to loadbearing or nonloadbearing concrete masonry assemblies, concrete masonry veneers correspondingly require their own set of guidelines to mitigate cracking.

These recommendations focus on cracking resulting from internal volume change of the concrete masonry. Potential cracking resulting from externally applied design loads due to wind, soil pressure, seismic forces, or differential settlement of foundations is controlled by the structural analysis and design, which is not addressed here. Where external loads are an issue in combination with internal volume change, the design should consider the combined effects of these influences on cracking.

Inherent within each one of these approaches to crack control is providing sufficient horizontal reinforcement to carry and distribute the tensile stresses that develop within the assembly. This horizontal reinforcement must be used in combination with control joints or relief joints to be effective. An additional important consideration with each of these approaches is their type of bond pattern used in the construction of the concrete masonry; with the two most common types being running bond and stack bond construction. TMS 402 (REF. 3) requires a minimum amount of horizontal reinforcement equal to 0.00028 multiplied by the gross vertical cross-section of the wall ($0.00028A_{Gv}$) for all masonry not laid in running bond to provide continuity across head joints. When applying the recommendations of this Tech Note to construction other than running bond, the minimum horizontal reinforcement used should be the larger of that required by TMS 402 or this Tech Note.

2.1 Crack Control Strategy Selection

Each option to mitigating shrinkage-related cracking in concrete masonry, whether empirical, engineered, or reinforced, has advantages and disadvantages depending on project-specific conditions. Figure 4 provides a decision matrix to aim in the selection of a crack control strategy. When considering which crack control strategy to implement, it's always prudent to verify with local manufacturers for regional guidance. The empirical and engineered crack control approaches work equally well with reinforced and unreinforced masonry if the minimum amount of prescriptive horizontal reinforcement per TABLES 1 OR 3 is provided. Using reinforced relief joints, however, is only practical with reinforced masonry designs; whereas veneers are exclusively an unreinforced cladding through the lens of design intent.

The empirical approach, while simple, straightforward, and easy to apply in common scenarios, tends to produce more conservative results when compared to the engineered method because it doesn't take into consideration project specific

conditions and material properties and instead is based upon relatively conservative assumptions. The empirical approach also doesn't offer the same flexibility the engineered method does with respect to building geometry and layout as it presumes relatively uniform, evenly spaced openings within a full height masonry wall.

Conversely, the engineered method offers both more flexibility in application and less conservative (larger) spacing of control joints. It does, however, require project-specific design criteria and foreknowledge of the linear drying shrinkage of the concrete masonry units to be used in construction to calculate the Crack Control Coefficient (CCC). It also typically requires more horizontal reinforcement compared to the empirical approach, which is only a cost consideration when this reinforcement isn't already present for resisting structural loads or other purposes. When more conservative assumptions are used in the determination of the CCC, the results tend to converge with those obtained using the empirical method.

The reinforced relief joint method is unique in that control joints are not required. While this maintains the continuity of shear walls, relief joints may still be necessary, which require consideration and coordination in the field. It is generally not economically viable to use this approach unless the horizontal reinforcement is already present for other structural purposes.

Regardless of which methodology is used, the use of horizontal reinforcement combined with properly located and spaced control joints or relief joints limits cracks to a width of 0.02 in. (0.51 mm). Because preventing all cracking from occurring is unfeasible, keeping the crack widths to less than 0.02 in. (0.51 mm) maintains both an aesthetically pleasing appearance while also allowing water repellent coatings to effectively resist water penetration for cracks of this size. The key objective to keep in mind with these recommendations is crack mitigation, not crack elimination.

3.0 EMPIRICAL CRACK CONTROL

3.1 Control Joint Locations

The empirical crack control method employs a combination of horizontal reinforcement and vertical control joints to relieve tensile stresses within the assembly and mitigate cracking potential. Control joints are essentially vertical planes of weakness built into the wall to reduce restraint, permit longitudinal movement, and relieve stress concentrations. A bond break is accomplished by replacing all or part of a vertical mortar joint with a backer rod and sealant. This keeps the joint weather tight while accommodating small movements. Horizontal control joints are not needed with concrete masonry walls as the assembly is not restrained from moving in the vertical direction.

Below grade walls traditionally do not incorporate control joints due to concerns with detailing the joint to withstand hydrostatic water pressures. Additionally, because foundation walls are subjected to relatively constant temperature and moisture conditions, shrinkage-induced movement below grade tends to be less significant than in above grade walls.

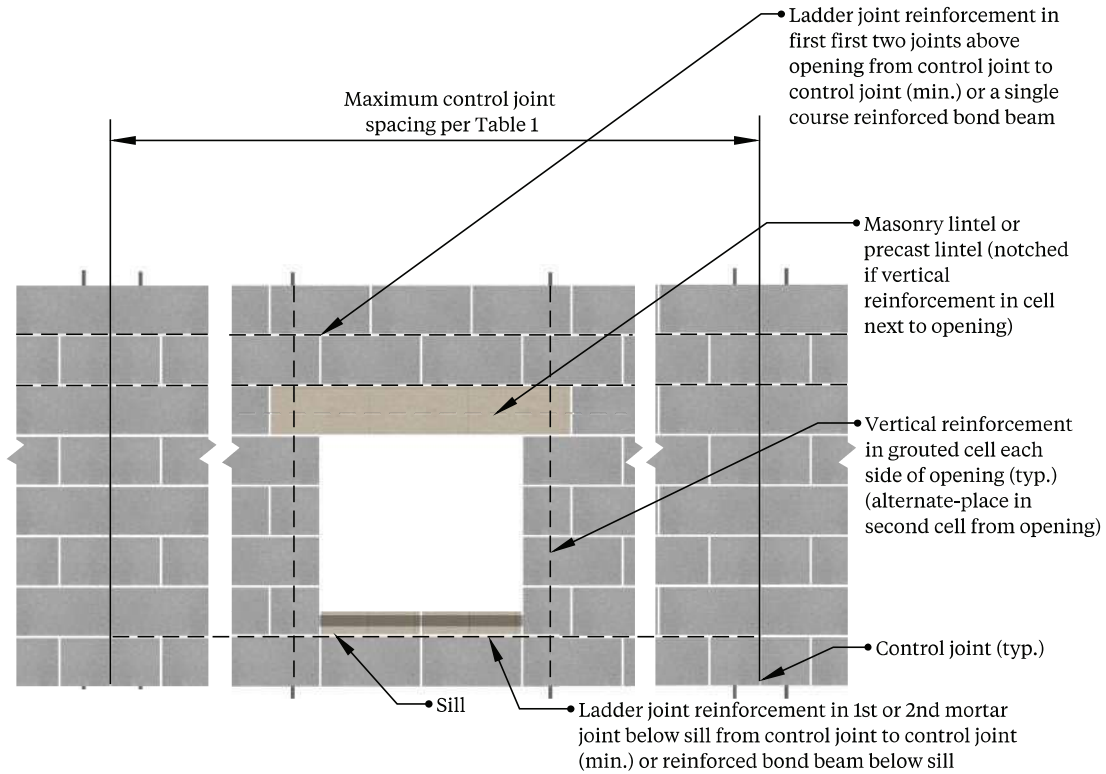

FIGURE 5A — Control Joint Detailing Around Reinforced Openings

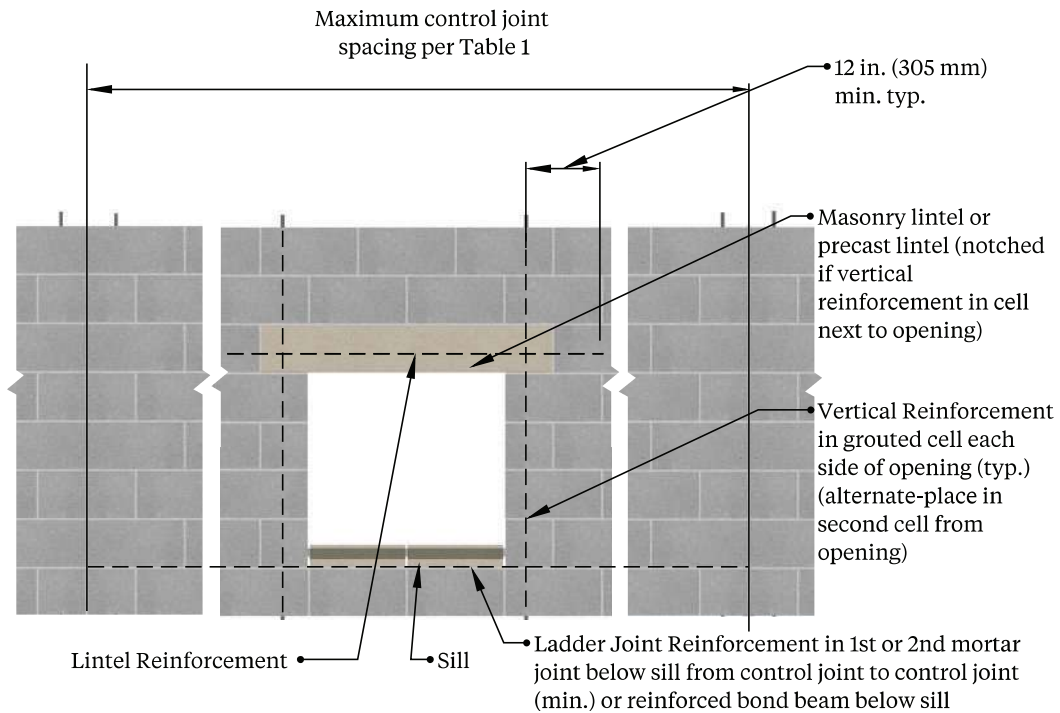

FIGURE 5B — Control Joint Detailing Around Reinforced Openings

When required, control joints should be located where volume changes in the masonry due to drying shrinkage, carbonation, or temperature changes are likely to create tension in the masonry that will exceed its tensile capacity. FIGURES 1 AND 2 highlight several common locations for stress concentrations, including:

- at changes in wall height;
- at changes in wall thickness or stiffness;
- at (above) movement joints in foundations;
- at (above and below) movement joints in roofs and floors;
- near one or both sides of openings; and
- adjacent to corners of walls or intersections.

Consideration must also be given to the effect of control joint placement on load distribution within the wall. For example, locating control joints at the ends of lintels likely compromises arching action (REF. 4G). Therefore, it may be prudent to design the lintel to carry the full weight of the wall above it in addition to any superimposed loads when control joints are located adjacent to openings. Additionally, incorporating control joints into shear walls effectively partitions the line of resistance

into multiple panels rather than one uninterrupted element for design purposes.

3.2 Control Joints at Openings

Because cracking occurs in the vertical planes of greatest weakness, openings in the masonry are particularly vulnerable. There are two general approaches to detailing around openings to mitigate shrinkage cracking: reinforced or isolation.

3.2.1 Reinforced Openings

When reinforcement is necessary around the opening to resist design loads or other reasons, or when the assembly is loadbearing or part of the lateral force-resisting system, a more practical solution is to locate the control joints away from the opening and provide adequate reinforcement above, below, and adjacent to the opening as illustrated in FIGURES 5A AND 5B. As these assemblies typically already have trim steel around the opening to resist design loads, this same reinforcement can be used to mitigate cracking around the opening allowing the control joints to be offset to facilitate construction. In addition to being easier to construct, reinforced openings have the advantage of not requiring shear transfer mechanisms in the panels above and below the opening as isolated openings often require.

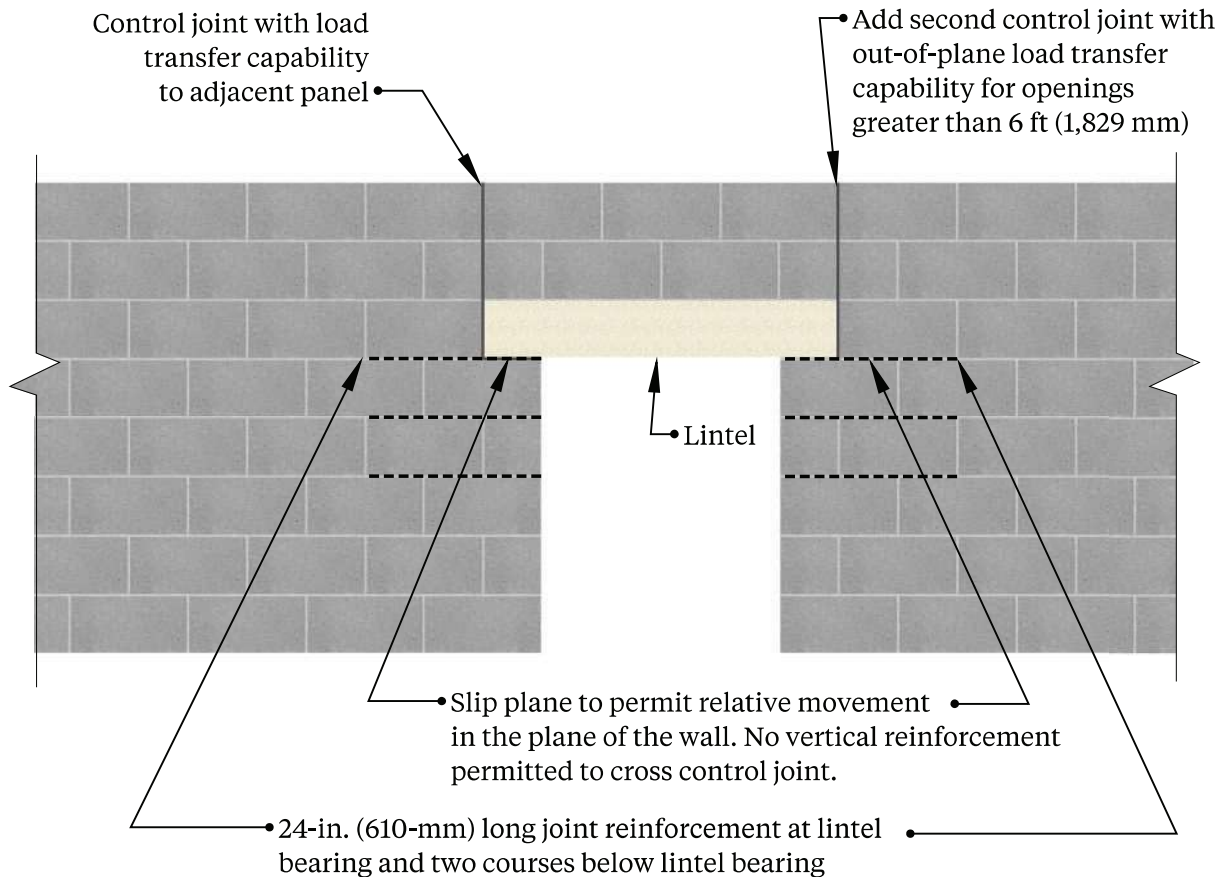

FIGURE 6 — Control Joint Detailing Around Isolated Openings

The preferred method of detailing around reinforced openings is shown in **FIGURE 5A** whereby reinforcing bars are placed in the first cell or course on each side of the opening and extended a minimum of 12 in. (305 mm) past the reinforcement it intersects. An alternative to this detailing practice is shown in **FIGURE 5B**, which may be more practical for some project conditions, such as when a steel lintel is used above the opening. Here, joint reinforcement may be placed in the first two mortar joints above the opening and extended to the control joint on each side as shown in **FIGURE 5B**. As an alternative, a combination of joint reinforcement and horizontal bond beams can be used at the same elevation.

3.2.2 Isolated Openings

One practice is to provide control joints directly adjacent to an opening in a masonry assembly similar to that illustrated in **FIGURES 6**. This isolates the masonry above and below the opening and allows movement independent of the surrounding field of masonry. Isolated openings are most appropriate for assemblies that have little to no reinforcement incorporated into the masonry near the opening, such as for nonloadbearing assemblies and partition walls.

For an isolated opening of up to 6 ft. (1.83 m) in length, a control joint should be placed at one side of the opening as shown in **FIGURE 6**. Allowance for movement must be provided between the bottom of the lintel and the masonry on which the lintel bears. This movement is accommodated by a slip plane, often flashing or other bond breaker detailed at the lintel bearing interface. Because the lintel and the masonry it is supporting is not laterally braced out-of-plane with this detail, control joints capable of providing out-of-plane load transfer across the control joints are required, such as the joints shown in **FIGURES 7A, 7D, 7E, 7F, 7H, 7I, AND 7J**.

To resist in-plane movement around the slip plane, horizontal joint reinforcement should be placed at the lintel bearing location and two courses below (four courses if using half-high concrete masonry units). The joint reinforcement should extend a minimum of 16 in. (406 mm) past the end of the lintel. While lintel bearing lengths are often 8 in. (203 mm), the bearing length may need to be increased based on the load from the lintel and the bearing capacity of the supporting masonry. If utilizing steel beams over openings in lieu of concrete masonry or precast lintels, it is critical that the steel beam not be welded to the bearing plate(s) where designated control joints are to be constructed, as this will pin the two sections together, restraining movement.

Although uncommon in wall assemblies where isolated openings are used (e.g., nonloadbearing walls, partitions, and similar lightly reinforced or unreinforced assemblies), the masonry panel above the opening may also be subjected to vertical uplift loads at the roofline that need to be accommodated. In **FIGURE 6**, continuous vertical reinforcement cannot be provided in the cell directly adjacent to the opening on the left, as crossing the horizontal portion of the control joint (i.e., the slip plane) would effectively pin the two sections together and restrain relative movement. Instead, a vertical shear transfer mechanism may

need to be provided between the masonry above the opening and the adjacent masonry similar to **FIGURES 7F, 7H, OR 7I** to resist uplift forces on the masonry above the opening.

For an isolated opening greater than 6 ft. (1.83 m) in length, a control joint should be provided and detailed on both sides of the opening.

3.3 Construction of Control Joints

Common control joint details are illustrated in **FIGURE 7**. Joint reinforcement and other horizontal reinforcement should be discontinued at control joints unless it is required for structural purposes, as it will act to restrain horizontal movement. (This is a key difference between control joints and reinforced relief joints, the latter of which maintains continuity of the reinforcement through the joint using specialized details.) Examples of structural reinforcement that must be continuous include bond beams at floor and roof levels that resist diaphragm chord tension.

When the transfer of out-of-plane loads between two panels separated by a control joint is not critical, the control joint detailing options shown in **FIGURES 7B AND 7C** can be used. Where desired, however, out-of-plane loads can be transferred between adjacent masonry panels separated by control joints by providing a shear key, as shown in **FIGURES 7A, 7D, 7E, 7F, 7H AND 7I**. **FIGURES 7F AND 7I** show smooth dowel bars placed across the control joint to transfer shear. These dowels are greased or placed in a plastic sleeve to prevent bond to the grout and allow unrestrained longitudinal movement within the plane of the wall. **FIGURE 7H** is a variation on this approach, where one horizontal bond beam reinforcing bar extends across the control joint, and is similarly de-bonded to allow longitudinal movement.

Control joints can also be constructed using sash units, which accommodate the shear key of a preformed control joint gasket, as shown in **FIGURE 7A**. The gaskets are generally available in either PVC, complying with ASTM D2287, *Standard Specification for Nonrigid Vinyl Chloride Polymer and Copolymer Molding and Extrusion Compounds* (**REF. 9**), or rubber compounds complying with ASTM D2000, *Standard Classification System for Rubber Products in Automotive Applications* (**REF. 10**). When used as a shear key to transfer out-of-plane loads between two panels separated by a control joint, the gasket material should be tested to determine its strength and applicability in this application. This information is generally available from the manufacturers of preformed gaskets.

FIGURE 7D shows a grouted shear key. For this joint, the out-of-plane load transfer mechanism is provided by filling the adjacent ends of two stretcher units with grout or mortar. To allow longitudinal movement, building paper or other material is installed to break the bond between the grout/mortar and one of the masonry units.

Control joints constructed with special unit shapes, as shown in **FIGURE 7E**, can also be used to provide out-of-plane load transfer. Before specifying this joint construction, however, the availability of these unit shapes should be verified with local

concrete masonry manufacturers. Care should be taken when constructing this type of control joint to ensure that excessive mortar is not placed in the head joint of the two control joint units, which can potentially lead to bonding of the two panels.

Where required, several control joints can be constructed to maintain the fire resistance rating of the base masonry assembly. FIGURES 7A, 7B, 7D, AND 7E illustrate fire rated control joint detailing options drawn from the requirements of ACI/TMS 216.1, *Code Requirements for Determining Fire Resistance of Concrete and Masonry Construction Assemblies* (REF. 12). TEK 07-01D (REF. 4A) provides more information on fire resistance ratings of concrete masonry assemblies.

Where concrete masonry is used as a backing for veneer or other applications where finishes are used, consider the following:

- Control joints should extend through the facing when wythes are rigidly bonded, such as plaster or adhered veneer applied directly to the concrete masonry units.
- Control joints need not extend through the facing when the bond between the two materials is flexible, such as anchored veneer with flexible ties. However, depending on the type of facing, considerations should be given to crack control in the facing material as well.
- When the concrete masonry wall is finished on both sides with a flexible cladding or a cladding attached with flexible connectors, control joints may be omitted as any potential shrinkage cracks that develop would be hidden from view and protected from weather

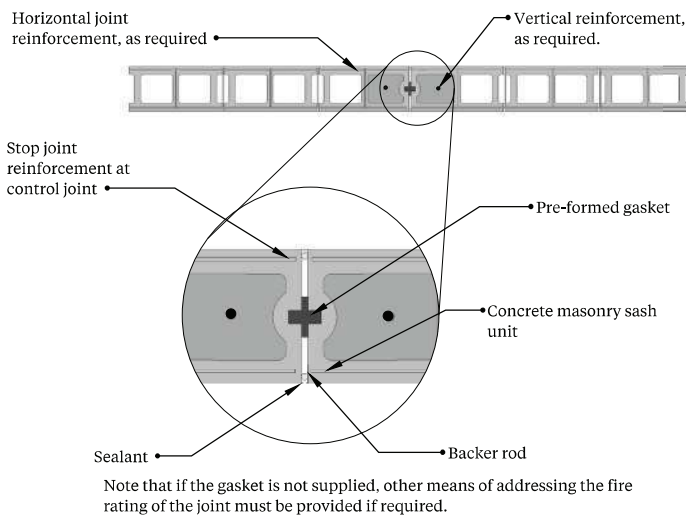

Figure 7a - Pre-formed gasket (2-hour fire rated)

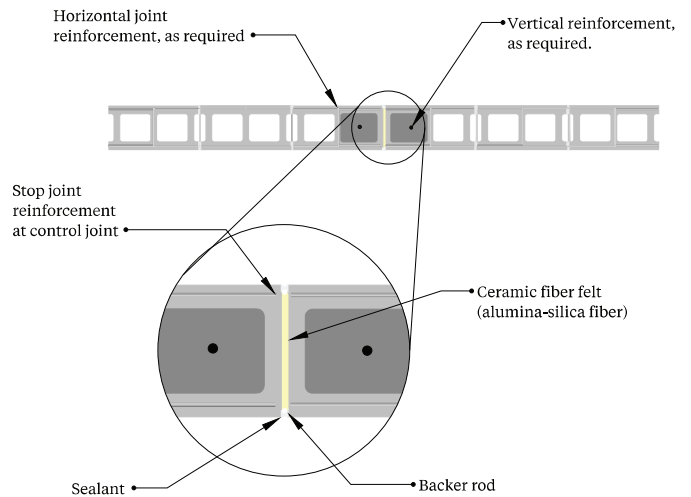

Figure 7b - 4-hour fire rated control joint*

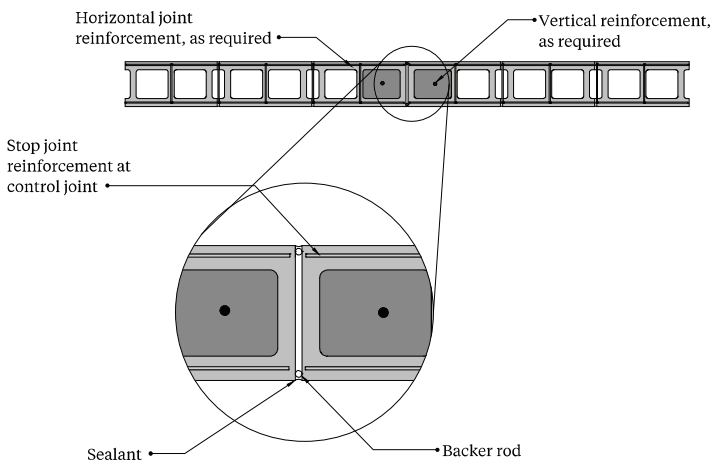

Figure 7c - Discontinuous reinforcement

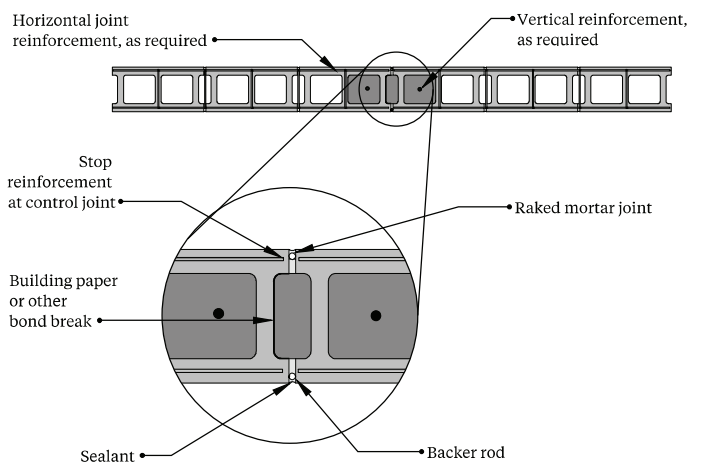

Figure 7d - Formed paper joint (4-hour fire rated)

FIGURE 7 — Typical Control Joint Details (continued on next page)

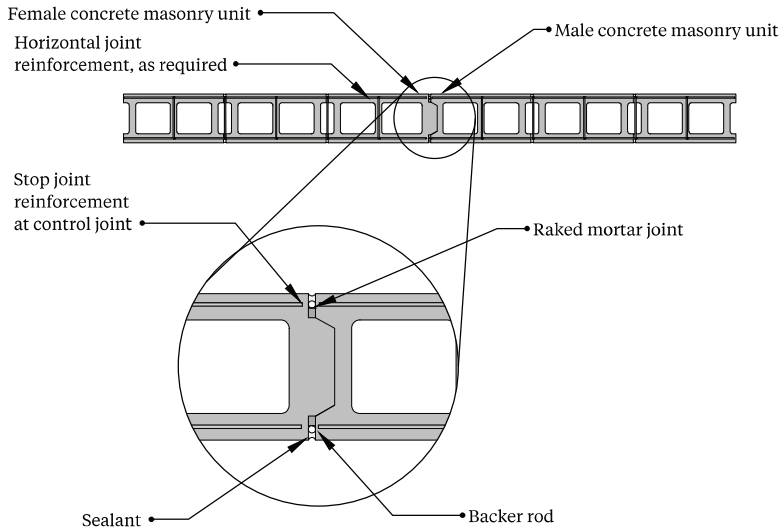

Figure 7e - Special-shaped units (4-hour fire rating)

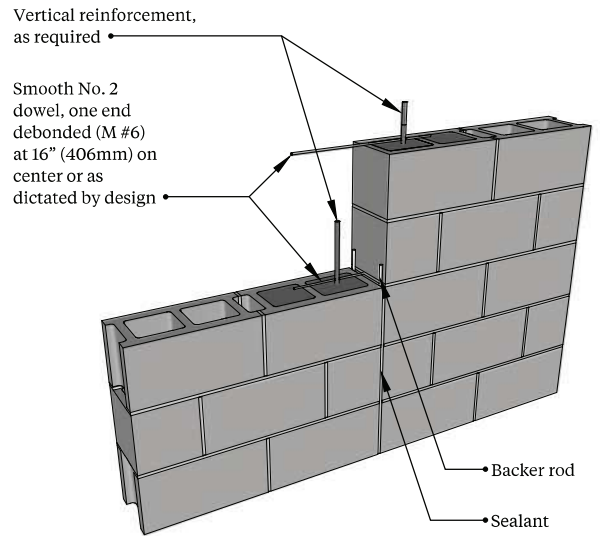

Figure 7f - Doweled joint (for shear transfer)

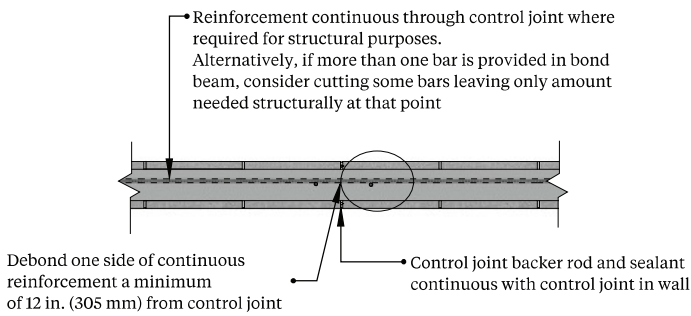
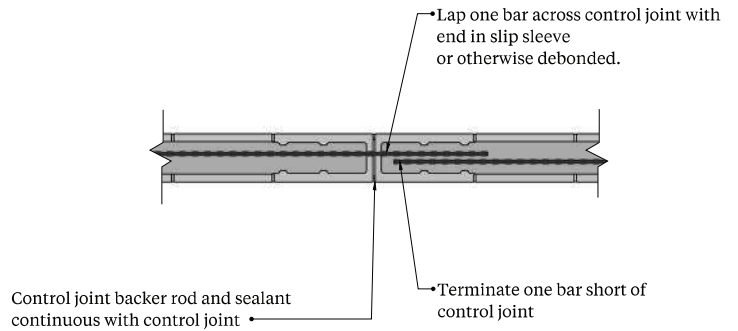

Figure 7g - Control joint through a bond beam - continuous horizontal reinforcement



7h - Control joint through a bond beam - continuous horizontal reinforcement

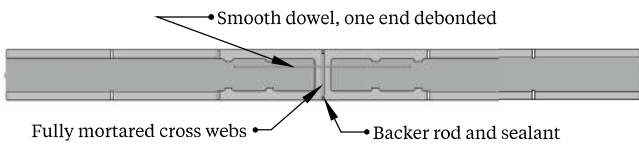

Figure 7i - Control joint through a bond beam - discontinuous horizontal reinforcement with dowel

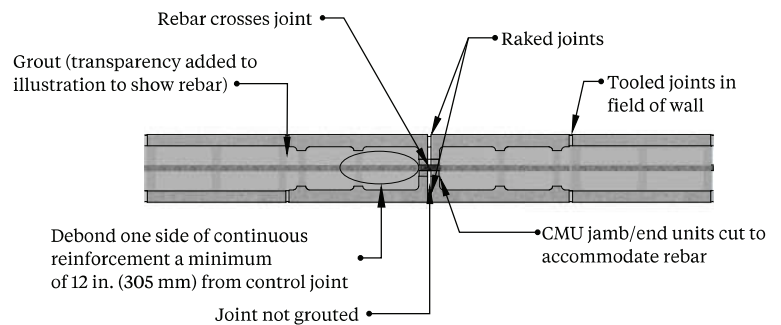

Figure 7j - Continuous horizontal reinforcement utilizing jamb units

FIGURE 7 — Typical Control Joint Details

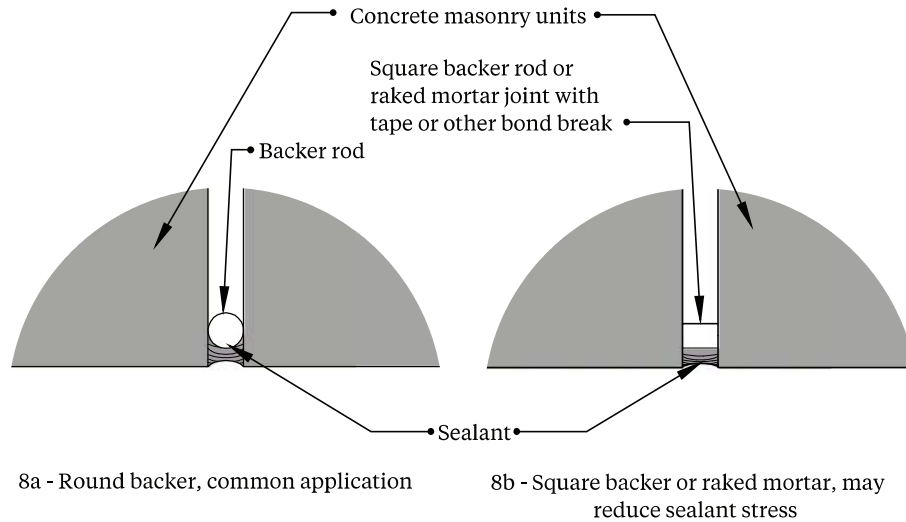

FIGURE 8 — Detail of Control Joint Surface

FIGURE 8 shows details of the surface of a typical concrete masonry control joint. To provide a joint that is sealed against the passage of air, water, and sound, caulking or other appropriate sealant is used. The backer rod provides a uniform foundation for the sealant to prolong its service life. Although the detail shown in **FIGURE 8A** is considered the typical construction, research suggests that the joint profile shown in **FIGURE 8B** may offer improved performance because the flat profile reduces peeling stresses at the corners of the sealant. The depth of sealant should be approximately one-half of the joint width to reduce sealant strain, and hence extend sealant life. See TEK 19-06A, *Joint Sealants for Concrete Masonry Walls* (**REF. 4B**) for more detailed information.

3.4 Control Joint Spacing

In addition to placing control joints at locations of stress concentration as illustrated in **FIGURE 1 AND 2**, control joints are used to effectively divide a length of wall into a series of isolated panels. **TABLE 1** defines recommended maximum spacing of control joints based on the empirical crack control recommendations. This criteria has been developed based on successful historical performance over many years in various geographical conditions using both reinforced and unreinforced masonry. The empirical method is the most commonly used method of locating control joints and is applicable to most building configurations and environmental conditions, however, control joint spacing may be adjusted up or down where local experience or project conditions warrant.

The recommendations of **TABLE 1** assume that units used in construction comply with the minimum requirements defined by one of the following concrete masonry unit standards:

- ASTM C55, *Standard Specification for Concrete Building Brick* (**REF. 5**);

- ASTM C90, *Standard Specification for Loadbearing Concrete Masonry Units* (**REF. 6**);
- ASTM C744, *Standard Specification for Prefaced Concrete and Calcium Silicate Masonry Units* (**REF. 7**); or
- ASTM C1634, *Standard Specification for Concrete Facing Brick* (**REF. 8**).

The recommendations in **TABLE 1** also assume that a minimum amount of horizontal reinforcement is provided between control joints as indicated in Footnotes 2 and 3. For units with a nominal height of 8 inches (203 mm), the minimum area of reinforcement given, 0.025 in.²/ft. (52.9 mm²/m) of height, translates to horizontal reinforcement spaced as indicated in **TABLE 3**. Similar to concrete masonry veneers, half high concrete masonry unit assemblies are installed with a larger percentage of mortar, which in turn has a larger potential for system shrinkage and therefore cracking potential. As such, the prescriptive crack control recommendations detailed in **TABLE 1** increase the area of horizontal reinforcement and decrease the maximum control joint spacing for assemblies constructed using half-high concrete masonry units. See **TABLE 4** for horizontal reinforcement spacing translating to 0.034 in.²/ft. (72.0 mm²/m) of height.

To illustrate the control joint spacing using the empirical crack control criteria, consider a 20 ft. (6.10 m) tall warehouse with walls 100 ft. (30.48 m) long constructed using 8 in. (203 mm) nominal height CMU. **TABLE 1** stipulates a maximum control joint spacing of the lesser of:

- A length-to-height ratio of 1.5 to 1, which corresponds to 1.5 x (20 ft.) = 30 ft. (9.14 m); or
- Control joints spaced every 25 ft.-4 in. (7.72 m).

In this example, the maximum spacing of 25 ft.-4 in. (7.72 m) governs over the length to height ratio. In addition to the control

joints at 25 ft.-4 in. (7.72 m), incorporating 9 gage (MW11) bed joint reinforcement at 16 in. (403 mm) on center satisfies the minimum horizontal reinforcement criterion per **TABLE 3**. For walls with masonry parapets, consider the parapet as part of the wall height when determining the length-to-height ratio if the parapet is bonded to the masonry below.

4.0 ENGINEERED CRACK CONTROL

While the empirical crack control method is the most commonly used method and is applicable to most concrete masonry construction, an alternative crack control design strategy is the engineered method. The engineered crack control criteria is often used with unusual project conditions occur (such as with an irregular building layout or wall geometry) or when project-specific information is known, such as the actual linear drying shrinkage for the concrete masonry units or temperature fluctuations that differ from what would be normally considered in design.

The engineered approach to controlling cracking combines the potential shrinkage due to drying, carbonation, and temperature into a single Crack Control Coefficient (CCC). In general, this engineered approach is more involved and requires more detailed knowledge of the masonry characteristics than the empirical approach. The engineered method, however, provides more reasonable solutions to unique project conditions such as dark colored units in climates with large temperature swings or wainscot assemblies where a 1.5 to 1 aspect ratio for control joint spacing results in an excessive number of control joints.

As with the empirical approach, the effectiveness of the engineered method depends on reliable criteria being correctly incorporated into the project design, the materials meeting the requirements of the project specifications, and the masonry being constructed in accordance with the project drawings. Once the internal movement due to volume change has been estimated with the CCC, the designer can control crack width to a maximum value through the combined use of control joints and horizontal reinforcement, similar to the empirical approach.

TABLE 3: Maximum Spacing of Horizontal Reinforcement to Provide 0.025 in.²/ft. (52.9 mm²/m) of Masonry Height	
Reinforcement Size	Maximum Spacing, in. (mm)
W1.7 (9 gage) (MW11) [^]	16 (406)
W2.1 (8 gage) (MW13) [^]	16 (406)
W2.8 (3/16 in.) (MW18) [^]	24 (610)
No. 3 (M#10)	48 (1,219)
[^] Minimum two wires per course.	

TABLE 4: Maximum Spacing of Horizontal Reinforcement to Provide 0.034 in.²/ft. (72.0 mm²/m) of Masonry Height	
Reinforcement Size	Maximum Spacing, in. (mm)
W1.7 (9 gage) (MW11) [^]	12 (305)
W2.1 (8 gage) (MW13) [^]	12 (305)
W2.8 (3/16 in.) (MW18) [^]	16 (406)
No. 3 (M#10)	40 (1,016)
[^] Minimum two wires per course.	

4.1 Crack Control Coefficient

The Crack Control Coefficient (CCC) is an indicator of anticipated wall shrinkage. Concrete masonry unit shortening per unit length is estimated by including the possible combined effects of movement due to drying shrinkage, carbonation shrinkage, and contraction due to temperature reduction. The Crack Control Coefficient value itself is determined by summing the coefficients of these three properties for a specific concrete masonry unit.

The total linear drying shrinkage is determined in accordance with ASTM C426 (REF. 2), which ASTM C90 (REF. 6) and other concrete masonry standards limits to 0.00065 in./in. (mm/mm). The measurement of the total linear drying shrinkage per ASTM C426 takes a concrete masonry unit from a fully saturated state to a nearly oven-dry condition and is therefore considered the maximum potential linear drying shrinkage. As this isn't a realistic range of moisture content for a concrete masonry unit in the field, TMS 402 (REF. 3) stipulates using 50% of the total linear drying shrinkage determined in accordance with ASTM C 26 (REF. 2).

While a drying shrinkage coefficient of 50% of the maximum permitted by ASTM standards (e.g., 0.000325 in./in. (mm/mm)) for concrete masonry units could be used, the advantage of applying the engineering crack control method is the actual measured drying shrinkage for the units to be used in construction can be used. Hence, if the measured linear drying shrinkage for a given unit was 0.0004 in./in. (mm/mm), in calculating the CCC 50% of this value would be used, or 0.0002 in./in. (mm/mm).

The coefficient of thermal expansion for concrete masonry units typically range from 0.0000025 to 0.0000055 in./in./°F (0.0000045 to 0.0000099 mm/mm/°C). While there are several factors that affect this material property, the unit density tends to be the largest driver, with units produced using lightweight aggregates being more stable to temperature fluctuations. For design purposes, a value of 0.000004 in./in./°F (0.0000081 mm/mm/°C) is assumed by TMS 402 (REF. 3), however, if the actual coefficient of thermal expansion is known, that value should be used.

The final source of shrinkage in calculating the CCC is from carbonation of the concrete masonry units, an irreversible chemical reaction between carbon dioxide in the atmosphere and hydrate cement in the units. Carbonation reactions begin soon after the unit is produced and continue for approximately 1-2 years depending on the exposure conditions. While there is no standardized test method for measuring carbonation shrinkage, some research has shown a value of 0.00025 in./in. (mm/mm) is appropriate in this application. It is also worth noting that a small portion of the linear drying shrinkage measured when testing in accordance with ASTM C426 can be attributed to carbonation shrinkage as there is no practical means of isolating the unit from atmospheric carbon dioxide during testing. As such, applying a carbonation shrinkage value of 0.00025 in./in. (mm/mm) tends to be conservative. Further, in recent years

new technologies have been developed that introduce high concentrations of CO2 during the production or curing phases of unit manufacturing as a means of sequestering carbon dioxide. These processes tend to accelerate the carbonation of the concrete masonry unit in the early days following production resulting in less carbonation-related shrinkage in the field.

To illustrate the calculation of the CCC, consider the following:

- Drying Shrinkage – Testing in accordance with ASTM C426 indicates a drying shrinkage potential of 0.0003 in./in. (mm/mm). For design, 50% of these value is used, or 0.00015 in./in. (mm/mm).
- Coefficient of Thermal Expansion – For design, assume a coefficient of thermal expansion of 0.000004 in./in./°F (0.0000081 mm/mm/°C) and a temperature change of 70°F (21.1°C). This would translate to a thermal contraction value of 0.00028 in./in. (mm/mm)
- Carbonation Shrinkage – If unit-specific carbonation shrinkage data is not available, assume a value of 0.00025 in./in. (mm/mm).

The Crack Control Coefficient (CCC) is then determined by summing these three parameters:

$$CCC = 0.00015 + 0.00028 + 0.00025 = 0.00068 \text{ in./in. (mm/mm)}$$

Applying the criteria of TABLE 2, because the CCC is less than 0.001 in./in. (mm/mm), the control joints for this example could be spaced up to 2.5 times the height of the wall, but not more than 25 ft.-4 in. (7.72 m). For most concrete masonry units and site conditions, the CCC varies from 0.0006 to 0.0011 in./in.(mm/mm). This range corresponds to a 100 ft (30.48 m) long wall shortening 0.72 to 1.32 in. (18.3 to 33.5 mm).

4.2 Horizontal Reinforcement

Using the calculated CCC, control joints are spaced using the criteria presented in TABLE 2 utilizing a minimum horizontal reinforcement ratio of $A_{SH}/A_{NV} > 0.0007$. TABLE 5 presents the maximum spacing of the various sizes of typical horizontal reinforcement to meet the 0.0007 criteria. The wall panel length-to-height ratio and the maximum length of wall panel criteria in combination with horizontal reinforcement in TABLE 2 are based on analytical studies verified with field studies.

4.3 Control Joints

Other than the calculation of the CCC under the engineering crack control approach, the overall detailing of the masonry assembly, including the use of isolated or reinforced openings and locating control joints at likely stress concentrations, is similar to the empirical approach. The one key difference with the engineered approach compared to the empirical method is that the anticipated joint opening at the control joint should be checked and the proper sealant material specified for the expected movement.

TABLE 5: Maximum Spacing of Horizontal Reinforcement to meet the Criteria $A_{SH} > 0.0007A_{NV}$ ^A

Wall Thickness, in. (mm)	Maximum spacing of horizontal reinforcement in. (mm) Reinforcement size				
	No. 5 (MW 16)	No. 4 (MW 13)	2 x 3/16 in. (MW 18)	2 x 8 gage (MW 13)	2 x 9 gage (MW 11)
Partially grouted walls ^B					
6 (152)	144 (3658)	128 (3251)	40 (1016)	24 (610)	24 (610)
8 (203)	144 (3658)	96 (2438)	32 (813)	24 (610)	16 (406)
10 (254)	136 (3458)	80 (2032)	16 (406)	16 (406)	16 (406)
12 (305)	120 (3048)	72 (1829)	16 (406)	16 (406)	16 (406)
Fully grouted walls					
6 (152)	72 (1829)	48 (1219)	8 (203)	8 (203)	8 (203)
8 (203)	56 (1422)	32 (813)	8 (203)	8 (203)	—
10 (254)	40 (1016)	24 (610)	8 (203)	—	—
12 (305)	32 (813)	24 (610)	—	—	—

^A A_{NV} includes cross-section area of grout in bond beams

^BFor partially grouted applications, the spacing of the grouted bond beams is equal to the spacing of the horizontal reinforcement shown.

For example, if the CCC for a given assembly is calculated to be 0.0008 in./in. (mm/mm) and control joints are spaced at 25 ft.-4 in. (7.72 m), the total anticipated panel shrinkage would be:

$$\text{Panel Shrinkage} = (0.0008)(25.33 \text{ ft.})(12 \text{ in./ft}) = 0.243 \text{ in. (6.2 mm)}$$

Assuming a control joint width of 3/8 in. (9.5 mm), the sealant used to weatherproof the control joints should be capable of at least 65% elongation calculated as follows:

$$(0.243/0.375)(100) = 65\%$$

5.0 CRACK CONTROL FOR ANCHORED CONCRETE BRICK AND OTHER CONCRETE MASONRY VENEERS

In anchored veneer applications, concrete brick can be used to provide a traditional clay masonry appearance, or alternatively, offering the flexibility available with the colors and architectural finishes of conventional concrete masonry products used as a veneer. Building with concrete veneers have some intrinsic differences from building with clay masonry due to different material properties. One should not be substituted for the other without due consideration of these differences.

Concrete masonry walls have an overall tendency to shrink, whereas clay brick walls tend to expand. Both concrete and clay masonry may use movement joints to accommodate this movement, although the type of joint is different for clay

masonry than for concrete masonry. When control joints are required, concrete brick requires only vertical control joints, whereas clay masonry typically requires both vertical and horizontal expansion joints to accommodate panel expansion.

Concrete masonry veneers are constructed using either concrete brick units, half-high concrete masonry units, or similar hollow or solid concrete masonry units. Concrete veneer units most commonly have a nominal thickness of 4 in. (102 mm), nominal lengths of 8, 10, 12 or 16 in. (203, 254, 305 or 406 mm) and nominal heights from 2.5 to 8 in. (64 to 203 mm).

When detailing concrete masonry veneers for crack control, many of the same strategies are used as with the empirical crack control method used for concrete masonry walls. The conventional empirical crack control recommendations, however, were developed for application to walls constructed using larger, hollow concrete masonry units, such as the common 8 x 8 x 16 in. (203 x 203 x 406 mm) CMU. The physical size differences of veneer units as well as the higher mortar surface area impacts how the concrete masonry veneer moves and reacts to changes in moisture content and temperature. Hence, crack control recommendations have been tailored specifically for concrete masonry veneers taking into consideration the following:

- Mortar: Using a lower compressive strength mortar helps ensure that if cracks do occur, they occur in the mortar joint rather than through the unit. Type N mortar is often specified for concrete masonry veneers because it tends to

be more flexible than other mortar Types containing a larger percentage of cement. ASTM C270, *Standard Specification for Mortar for Unit Masonry* (REF. 11) recommends Type O mortar for exterior veneers where the masonry is unlikely to be frozen when saturated, or unlikely to be subjected to high winds or other significant lateral loads. For other cases, Type N mortars should be specified for masonry veneer.

- **Joint Reinforcement:** Unlike full-size concrete masonry units, concrete masonry veneers cannot readily accommodate reinforcement in horizontal bond beams; limiting the option of horizontal reinforcement to joint reinforcement. Per **TABLE 1**, the minimum amount of horizontal reinforcement provided should be 0.034 in.²/ft. (72.0 mm²/m), which according to Table 4 can be easily accommodated with two wires of 9 gage (MW11) joint reinforcement spaced at 12 in. (305 mm) on center. The joint reinforcement should be discontinued at the control joint to avoid restricting horizontal movement at the joint.
- **Control Joint Locations:** Ideally, a control joint should be located wherever masonry volume changes are likely to cause cracking as shown in **FIGURE 1**. For veneer panels without openings or other points of stress concentration, control joints are used to effectively divide a wall into a series of panels. In general, it is desirable to keep these panels as square as possible to minimize cracking between the control joints. When this is not possible, the panel length to height ratio should be limited to 1.5, with a maximum control joint spacing of 20 ft. (6.1 m) as summarized in **TABLE 1**. Because veneers by their nature are unreinforced, detailing veneers should following the practices outlined for isolated openings covered under the empirical crack control criteria. Note that every opening does not necessarily require control joint(s) and control joint spacing should be adjusted where local experience justifies.
- **Control Joint Construction:** Structural masonry walls require that control joints permit free longitudinal movement while often resisting structural loads. Because veneers are nonstructural, veneer control joints need only permit unrestricted longitudinal movement. This can be accomplished by raking out the mortar joint and installing a backer rod and appropriate sealant. Typical control joint details for concrete masonry veneers are shown in **FIGURES 9, 10 AND 11**. The backer rod and sealant allows in-plane movement while keeping the joint weather tight. Several strategies are used to make control joints less noticeable. Perhaps the simplest approach is to locate the vertical control joint behind a downspout. If the architectural style allows it, a recess can be built into the veneer to create a vertical shadow line and provide an inconspicuous control joint location, or the control joint can be aligned with another architectural feature. When quoins are used, the control joint can be placed adjacent to the edge of the quoin to make it less noticeable.

- **Backing:** Veneers are attached to a structural backup with adjustable ties or anchors (for tie and anchor types, design criteria, and spacing requirements, see TEK 12-01B (REF. 4D)). Ties should be placed within 12 in. (305 mm) of the control joint in the veneer. When the backing includes a movement joint, it is good practice to align the veneer control joint with the backing movement joint. When the backing is light frame wood or steel construction, control joints should also be located within 4 in. (102 mm) of outside corners in high seismic risk areas. This has less to do with shrinkage related cracking and more with providing isolation at the corner. Without the control joint at the corner, past research has shown that the veneer acts more like a flanged element collecting and carrying load the light frame backing was intended to resist resulting in premature failure during a seismic event.
- **Multi-Story Construction:** Horizontal movement joints or isolation joints may be needed in multi-story concrete masonry veneer assemblies to accommodate differential movement between the veneer and the backing or to accommodate varying support element stiffnesses. (For example, a single veneer façade may have locations where it is vertically supported at the foundation, by light frame backing over openings, and at horizontal locations such as rooflines and decks. Consideration of such details is particularly important with multi-story wood frame backing, which undergoes vertical shrinkage as the wood loses moisture.

6.0 NO CONTROL JOINTS – HORIZONTAL REINFORCEMENT ONLY

In some regions of the country, significant amounts of horizontal reinforcement are required for structural purposes, for example in areas of high seismicity. When sufficient horizontal reinforcement is provided for structural purposes, it is effective to control cracking without the use of control joints. It has also been shown that horizontal reinforcement provides internal restraint, which results in transfer of tension from the masonry to the reinforcement, resulting in more frequent but much smaller cracks. As the level of horizontal reinforcement increases, cracking becomes more uniformly distributed and crack width decreases.

When a crack is formed, tension in the masonry is released. This masonry tension is transferred to the reinforcement at the time of crack formation. Therefore, reinforcement should be sized such that the resulting tensile force in the reinforcement does not exceed the yield strength of the steel. This keeps the steel within the elastic range and minimizes the crack width to a point where control joints are not necessary in the design.

As the horizontal reinforcement ratio (cross-sectional area of horizontal steel vs. vertical cross-sectional area of masonry) increases, crack width decreases. Smaller sized reinforcement at closer spacing is more effective than larger reinforcement at wider spacing. As such, the maximum spacing of the horizontal reinforcement should not exceed 48 in. (1,219 mm).

To ensure the steel is within the elastic range (the reinforcement strain is less than 0.002 in./in. (mm/mm) for Grade 60 (Grade 414) reinforcement) while shrinkage occurs and to limit the maximum average crack width to 0.02 in. (0.51 mm) a minimum cross-sectional area of reinforcement

$$A_{SH} \geq 0.002A_{NV}$$

TABLE 6 indicates the amount of horizontal reinforcement that will meet the $0.002A_{NV}$ criteria for various concrete masonry walls. Even though control joints may not be needed when $A_{SH} \geq 0.002A_{NV}$, reinforced relief joints may be necessary similar to those shown in FIGURES 7G AND 7J.

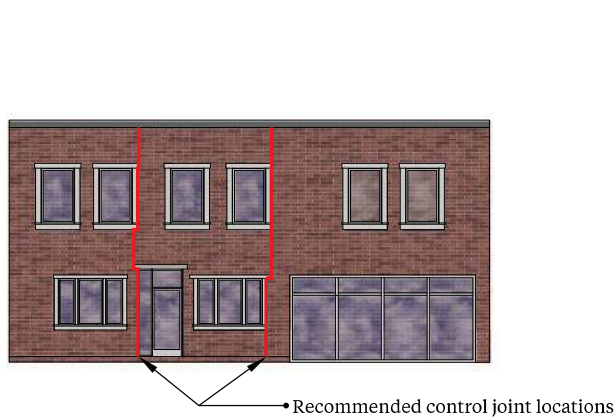

FIGURE 9—Example of Veneer Control Joint Placement

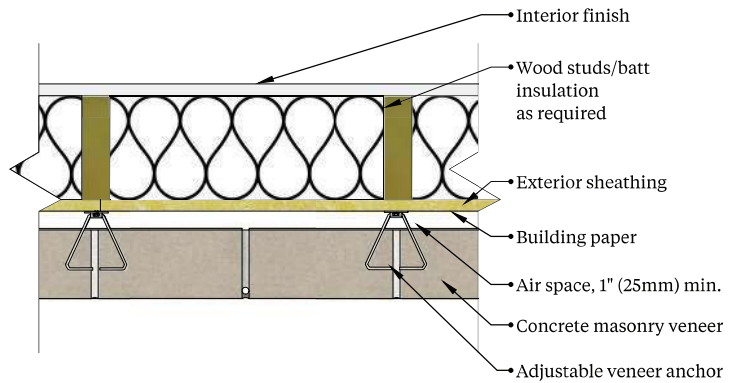

FIGURE 10—Concrete Masonry Veneer Over Wood Studs

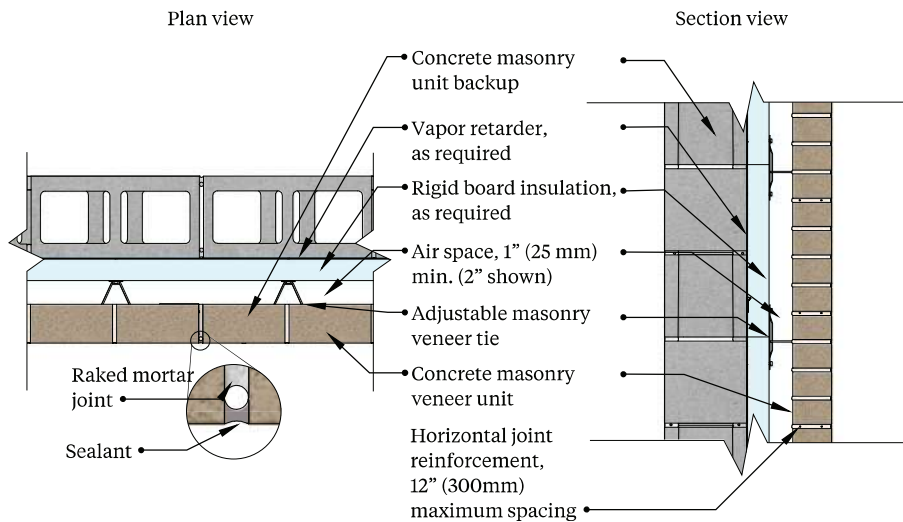

FIGURE 11—Typical Concrete Brick Veneer Control Joint

TABLE 6: Maximum Spacing of Horizontal Reinforcement to Meet the Criteria $A_{SH} > 0.002A_{NV}$ ^A

Wall thickness, in. (mm)	Maximum spacing of horizontal reinforcement, in. (mm) Reinforcement size		
	No. 6 (MW 19)	No. 5 (MW 16)	No. 4 (MW 13)
Partially grouted walls			
6 (152)	48 (1219)	48 (1219)	32 (813)
8 (203)	48 (1219)	40 (1016)	24 (610)
10 (254)	48 (1219)	32 (813)	16 (406)
12 (305)	48 (1219)	24 (610)	8 (203)
Fully grouted walls			
6 (152)	32 (813)	24 (610)	16 (406)
8 (203)	24 (610)	16 (406)	8 (203)
10 (254)	16 (406)	16 (406)	8 (203)
12 (305)	16 (406)	8 (203)	8 (203)

^A A_{nv} includes cross-sectional area of grout in bond beams.

²For partially grouted walls, the spacing of the bond beams is assumed equal to the spacing of the horizontal reinforcement shown in the table.

NOTATIONS

A_{GV} = Gross vertical cross-sectional area of the masonry assembly, in.² (mm²).

A_{NV} = Net vertical cross-sectional area of the masonry assembly, in.² (mm²).

A_{SH} = Net cross-sectional area of the horizontal reinforcement, in.² (mm²).

l = design span length, in. (mm)

REFERENCES

1. Measuring Shrinkage of Concrete Block – A Comparison of Test Methods, E. L. Saxer and H. T. Toennis, Proceedings of the 1957 ASTM Masonry Symposium, Pages 988-1004, ASTM International, www.astm.org.
2. *Standard Test Method for Linear Drying Shrinkage of Concrete Masonry Units*, ASTM C426 (all editions), ASTM International, www.astm.org.
3. *Building Code Requirements and Specification for Masonry Structures*, TMS 402/602-16, The Masonry Society, www.masonrysociety.org
- 3A. TMS 402-13, The Masonry Society, 2013, www.masonrysociety.org.
- 3B. TMS 402-16, The Masonry Society, 2016, www.masonrysociety.org.
- 3C. TMS 402-22, The Masonry Society, 2016, www.masonrysociety.org.
4. Tech Notes, Concrete Masonry and Hardscapes Association, www.masonryandhardscapes.org;
- 4A. TEK 07-01D, *Fire Resistance Ratings of Concrete Masonry Assemblies*.
- 4B. TEK 19-06A, *Joint Sealants for Concrete Masonry Walls*.
- 4C. TEK 05-02A, *Clay & Concrete Masonry Banding Details*.
- 4D. TEK 12-01B, *Anchors and Ties for Masonry*.
5. *Standard Specification for Concrete Building Brick*, ASTM C55 (all editions), ASTM International, www.astm.org
6. *Standard Specification for Loadbearing Concrete Masonry Units*, ASTM C90 (all editions), ASTM International, www.astm.org.
7. *Standard Specification for prefaced Concrete and Calcium Silicate Masonry Units*, ASTM C744 (all editions), ASTM International, www.astm.org.
8. *Standard Specification for Concrete Facing Brick*, ASTM C1634 (all editions), ASTM International, www.astm.org.
9. *Standard Specification for Nonrigid Vinyl Chloride Polymer and Copolymer Molding and Extrusion Compounds*, ASTM D2287 (all editions). ASTM International, www.astm.org.
10. *Standard Classification System for Rubber Products in Automotive Applications*, ASTM D2000, ASTM International, www.astm.org.
11. *Standard Specification for Mortar for Unit Masonry*, ASTM C270, ASTM International, www.astm.org.
12. *Code Requirements for Determining Fire Resistance of Concrete and Masonry Construction Assemblies*, ACI/TMS 216.1-14(19), American Concrete Institute, www.concrete.org.

COMMONLY ASKED QUESTIONS

Are there any special crack control considerations with integrally insulated concrete masonry walls?

When incorporating insulation between the face shells of a concrete masonry unit, whether insulation inserts or foam-in-place insulation, the crack control recommendations outlined in this TEK are appropriate to apply. One special consideration for systems that contain a near continuous layer of insulation inserts is to incorporate horizontal joint reinforcement into the mortar joints and not rely solely on bond beams for shrinkage reinforcement. Because the insulation layer acts to thermally isolate the exterior face shell from the conditioned interior, a large temperature gradient can develop within the cross-section of the assembly. Therefore, having horizontal reinforcement on both sides of the insulation layer aids in mitigating cracking for both exposure conditions.

Where the assembly is constructed using a system where the inside and outside face shells are not structurally connected by webs meeting the requirements of ASTM C90, however, the system should be detailed as a concrete masonry veneer over a concrete masonry backing.

Are control joints/relief joints always required?

There are many scenarios where concrete masonry structures have been built without control joints with no adverse

performance due to cracking. These tend to be smaller ancillary structures and single family residential construction where the size of the structure isn't large enough to generate sufficient movement due to shrinkage to result in cracking. Similarly, below grade concrete masonry construction often does not incorporate control joints as the fluctuations in temperature and moisture are relatively small.

It is also possible to detail a concrete masonry backing without control joints where both faces are finished with a system that isn't rigidly attached to the backing thereby allowing any cracks that form in the backing to not propagate through the finish system; for example, gypsum wallboard framed out on the interior and an anchored veneer attached to the exterior. This approach, however, would still need to consider any potential material needs on the cavity side of the backing to address water infiltration and air infiltration/exfiltration.

If using an adhered veneer directly bonded to a concrete masonry backing, should the control joints extend through the adhered veneer?

Yes. Any finish or cladding system that is rigidly attached or bonded to the concrete masonry backing should have the control joints extend through to the exterior surface of the finish. Similarly, units of an adhered veneer should not be installed where they span over a control joint as cracking in these scenarios is almost guaranteed.

ABOUT CMHA

The Concrete Masonry & Hardscapes Association (CMHA) represents a unification of the Interlocking Concrete Pavement Institute (ICPI) and National Concrete Masonry Association (NCMA). CMHA is a trade association representing US and Canadian producers and suppliers in the concrete masonry and hardscape industry, as well as contractors of interlocking concrete pavement and segmental retaining walls. CMHA is the authority for segmental concrete products and systems, which are the best value and preferred choice for resilient pavement, structures, and living spaces. CMHA is dedicated to the advancement of these building systems through research, promotion, education, and the development of manufacturing guides, design codes and resources, testing standards, and construction practices.

Disclaimer:

The content of this CMHA Tech Note is intended for use only as a guideline and is made available "as is." It is not intended for use or reliance upon as an industry standard, certification or as a specification. CMHA and those companies disseminating the technical information contained in the Tech Note make no promises, representations or warranties of any kind, expressed or implied, as to the accuracy or completeness of content contained in the Tech Note and disclaim any liability for damages or injuries resulting from the use or reliance upon the content of Tech Note. Professional assistance should be sought with respect to the design, specifications, and construction of each project.